



To :

Date : 20061214

TFT LCD
OSD057VA01CT

ACCEPTED BY :

| APPROVED BY | CHECKED BY | PREPARED BY |
|-------------|------------|-------------|
| | | |

| | | | |
|---------|-------------|-------------|------------|
| Doc.No: | OSD57VA01CT | Issue Date: | 2006/11/07 |
|---------|-------------|-------------|------------|

CONTENTS

| | |
|---|-----------|
| 1. OVERVIEW | 4 |
| 2. ABSOLUTE MAXIMUM RATINGS | 5 |
| 3. ELECTRICAL CHARACTERISTICS | 6 |
| 3.1TFT LCD | 6 |
| 3.2TFT-LCD current consumption..... | 6 |
| 3.3 Power 、Signal sequence..... | 7 |
| 4. INTERFACE CONNECTION | 8 |
| 5. INPUT SIGNAL(DE ONLY MODE) | 10 |
| 5.1 Timing Specification | 10 |
| 5.2 Timing sequence(Timing chart)..... | 11 |
| 5.3 Color Data Assignment..... | 12 |
| 6. CHARACTERISTIC OF TOUCH PANEL | 13 |
| 6.1 Basis characteristic | 13 |
| 6.2 Design guideline for Touch-Panel..... | 13 |
| 6.3 Circuit Diagram | 14 |
| 7. BLOCK DIAGRAM | 14 |
| 8. MECHANICAL DIMENSION | 15 |
| 8.1 Front Side | 16 |
| 8.2 Rear Side | 17 |
| 9. OPTICAL CHARACTERISTICS | 18 |
| 10. RELIABILITY TEST | 20 |
| 10-1. Temperature and humidity..... | 20 |
| 10-2. Shock and Vibration | 20 |
| 10-3. Judgment standard | 20 |

1. OVERVIEW

OSD057VAO1CT is 5.7 " color TFT-LCD(Thin Film Transistor Liquid Crystal Display)module composed of LCD panel,driver ICs,control circuit,and LED backlight.

The 14.52cm(5.7") screen produces a high resolution image that is composed of 640×480 pixel elements in a stripe arrangement.Display 262K colors by 6 Bit R.G.B signal input.Use 3.3 Voltage to drive the power of LCD system,and 5 Voltage to drive the black light LED.

General specifications are summarized in the following table:

| ITEM | SPECIFICATION |
|--------------------------------|------------------------------|
| Panel Size | 5.7 inch(panel diagonal) |
| Display Area (mm) | 116.16(W)×87.12(H) |
| Number of Pixels | 640×3(H)×480(V) |
| Pixel Pitch (mm) | 0.1815(H)×0.1815(V) |
| Color Pixel Arrangement | RGB vertical stripe |
| Display Mode | Normally white |
| Number of colors | 262,144 |
| Viewing Direction | 6 o'clock |
| Response Time (Tr+Tf) | 30ms |
| Brightness(cd/m ²) | 180nit(typ) |
| NTSC ratio | 50% |
| Viewing Angle(BL on,CR ≥ 10) | 140 degree(H) · 100degree(V) |
| Electrical Interface(data) | TTL |
| Power consumption(W) | 2.1 |
| Outline Dimension(in mm) | 127(W)×100(H)×7.65(D) |
| Weight(g) | ~132g |
| BL unit | LED |
| Surface Treatment | Anti-Glare · Hardness:3H |
| Type of touch screen | 4 Wire resistance type |

2. ABSOLUTE MAXIMUM RATINGS

| Item | Symbol | Min. | Max. | Unit | Note |
|-----------------------|-------------------------------|------|-----------|------|------|
| Power Supply Voltage | Vcc | -0.5 | 5.0 | V | |
| Signal Input Voltage | DCLK,DE,R0,G0 ,B0~R5,G5,B5 | -0.5 | Vcc + 0.5 | V | |
| Static Electricity | VESDc | -200 | +200 | V | *2) |
| | VESDm | -15K | +15K | V | |
| ICC Rush Current | IRUSH | - | 1 | A | *3) |
| Operation Temperature | T _{op} | -30 | 85 | °C | *1) |
| Storage Temperature | T _{stg} | -40 | 90 | °C | *1) |

Remarks :

*1) If users use the product out off the environment operation range (temperature and humidity) ,it will concern for visual quality.

*2) Test Condition: IEC 61000-4-2 ,

VESDc : Contact discharge to input connector

VESDm : Contact discharge to module

*3) The input pulse-current measurement system as below :

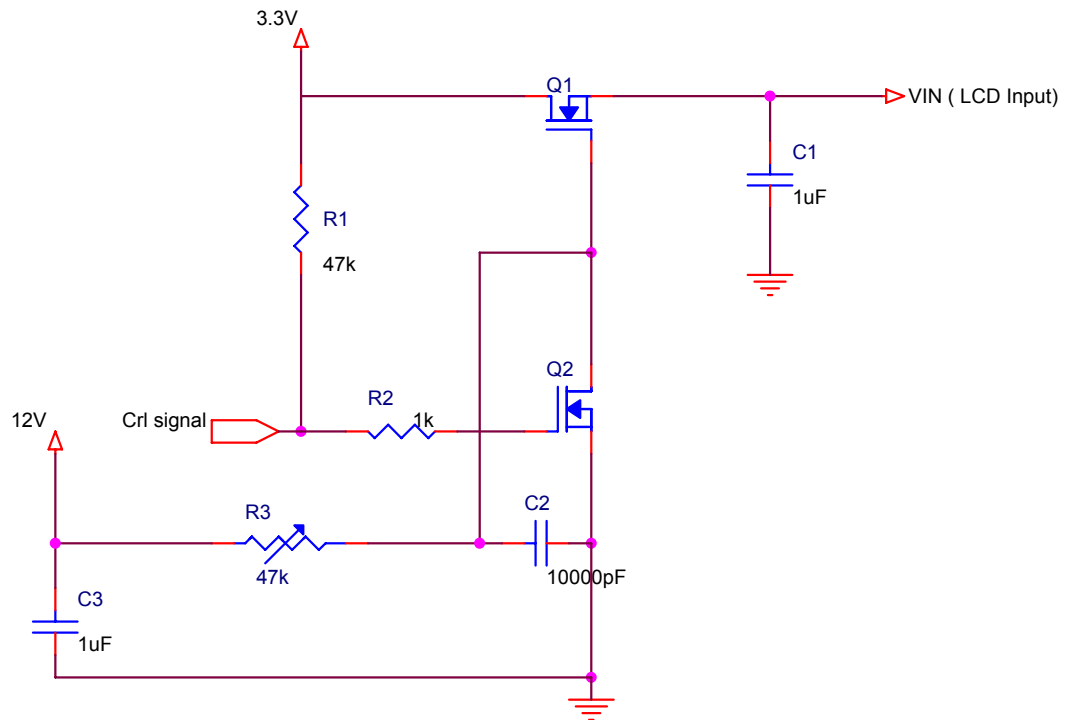

Control signal:High(+3.3V)→Low(GND)

Supply Voltage of rising time should be from R3 and C2 tune to 550 us.

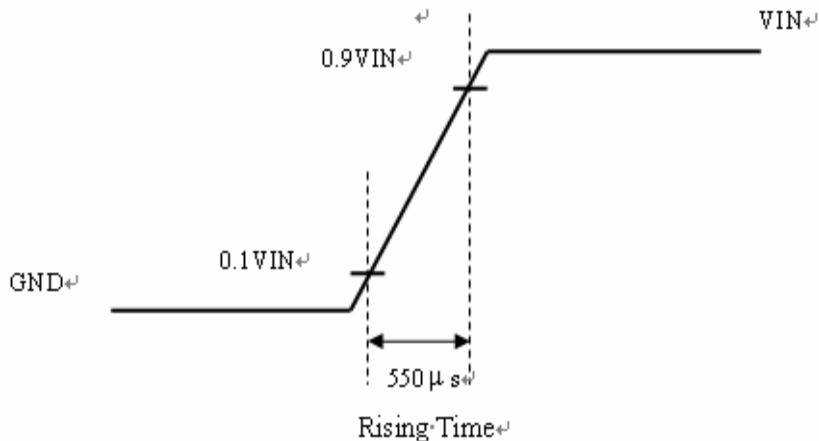

*4) Ifp Conditions : Pulse Width=10msec and Duty=1/10 °

3. ELECTRICAL CHARACTERISTICS

3.1TFT LCD

Ta=25°C

| Item | Symbol | Min. | Typ | Max. | Unit | Note |
|------------------------------|-----------|--------------------|-----|--------------------|------|------|
| Power Supply Voltage For LCD | V_{CC} | 3.0 | 3.3 | 3.6 | V | *1) |
| Power Supply Voltage For LED | V_{LED} | 4.5 | 5 | 5.5 | V | |
| Logic Input Voltage | V_{IH} | $V_{CC} \cdot 0.7$ | -- | V_{CC} | V | |
| | V_{IL} | 0 | -- | $V_{CC} \cdot 0.3$ | V | |

Remarks :

*1) V_{CC} -dip condition:

When $2.7\text{V} \leq V_{CC} < 3.0\text{V}$, $t_d \leq 10\text{ms}$.

$V_{CC} > 3.0\text{V}$, V_{CC} -dip condition should be same as V_{CC} -turn-on condition.

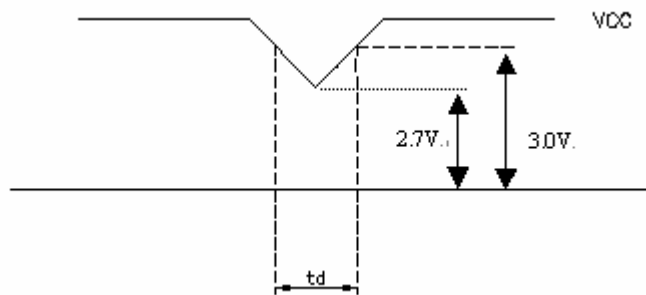

3.2TFT-LCD current consumption

| Item | Symbol | Min. | Typ | Max. | Unit | Note |
|-------------------|-----------|------|-----|------|------|------|
| LCD power current | I_{CC} | -- | 150 | 190 | mA | *1) |
| LED power current | I_{LED} | -- | 320 | 360 | mA | *2) |

*1) Typical: Under 64 gray pattern

Maximum: Under black pattern



·· (a)64 Gray Pattern·····

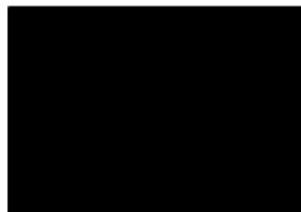

····· (b)Black Pattern·····

*2) Typical: When V_{LED} is 5.0V

Maximum: When V_{LED} is 4.5V

3.3 Power 、 Signal sequence

$t1 \leq 10\text{ms}$ $1 \text{ sec} \leq t5$
 $50\text{ms} \leq t2$ $200\text{ms} \leq t6$
 $0 < t3 \leq 50\text{ms}$ $200\text{ms} \leq t7$
 $0 < t4 \leq 10\text{ms}$

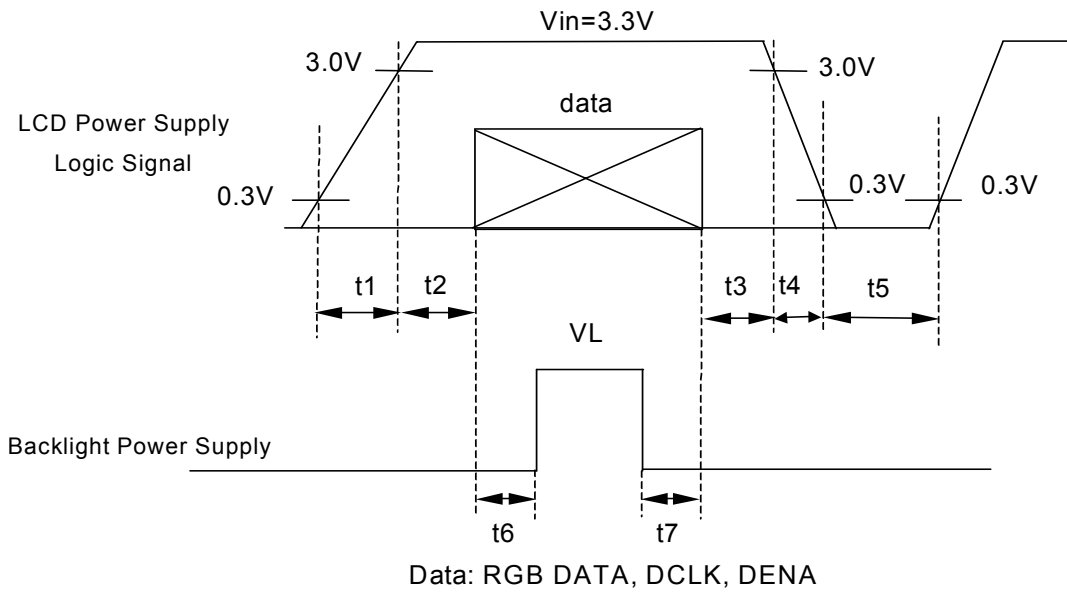

4. INTERFACE CONNECTION

(Connector type:40pin/0.5mm pitch/Bottom contact)-089N40-000R00-G2

| Pin NO. | SYMBOL | DESCRIPTION |
|---------|-----------------|---|
| 1 | U/D | Up or Down Display Control |
| 2 | NC or DMS | NC or Selection DE (Customer non-connect ; initial pull high =DE mod) |
| 3 | NC | NC |
| 4 | Vcc | Power Supply for Digital Circuit LED |
| 5 | Vcc | Power Supply for Digital Circuit LED |
| 6 | Vcc | Power Supply for Digital Circuit LED |
| 7 | Vcc | Power Supply for Digital Circuit LCD |
| 8 | NC | NC |
| 9 | DE | Data Enable |
| 10 | XL | Touchscreen |
| 11 | YU | Touchscreen |
| 12 | ADJ | Adjust for LED brightness |
| 13 | B5 | Blue Data 5 (MSB) |
| 14 | B4 | Blue Data 4 |
| 15 | B3 | Blue Data 3 |
| 16 | V _{ss} | Power Ground |
| 17 | B2 | Blue Data 2 |
| 18 | B1 | Blue Data 1 |
| 19 | B0 | Blue Data 0 (LSB) |
| 20 | V _{ss} | Power Ground |
| 21 | G5 | Green Data 5 (MSB) |
| 22 | G4 | Green Data 4 |
| 23 | G3 | Green Data 3 |
| 24 | V _{ss} | Power Ground |
| 25 | G2 | Green Data 2 |
| 26 | G1 | Green Data 1 |
| 27 | G0 | Green Data 0 (LSB) |
| 28 | V _{ss} | Power Ground |
| 29 | R5 | Red Data 5 (MSB) |
| 30 | R4 | Red Data 4 |
| 31 | R3 | Red Data 3 |
| 32 | V _{ss} | Power Ground |
| 33 | R2 | Red Data 2 |
| 34 | R1 | Red Data 1 |
| 35 | R0 | Red Data 0 (LSB) |
| 36 | XR | Touchscreen |
| 37 | YD | Touchscreen |
| 38 | DCLK | Clock Signals |
| 39 | V | Power Ground |
| 40 | L/R | Left or Right Display Control |

Remarks

1).ADJ adjust brightness to control Pin · Pulse duty the bigger the brighter.



2) ADJ signal =0~3.3V , operation frequency:20KHZ

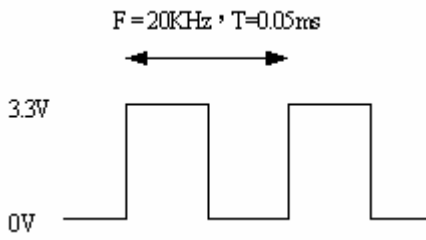

3) GND Pin must ground contact , can not be floating.

4) U/D and L/R are controled function

| L/R | U/D | Function |
|-----|-----|--|
| 1 | 0 | Normally display |
| 0 | 0 | Left and Right opposite |
| 1 | 1 | Up and Down opposite |
| 0 | 1 | Left and Right opposite , Up and Down opposite |

5. INPUT SIGNAL(DE ONLY MODE)

5.1 Timing Specification

| ITEM | | SYMBOL | MIN. | TYP. | MAX. | UNIT |
|--------------------|-------------------|-----------|-------|------|------|-----------|
| DCLK | Period | t_{CLK} | 16.67 | | | ns |
| | Dot Clock | f_{CLK} | 5 | 25 | 40 | MHz |
| | Low Level Width | t_{WCL} | 0.3 | - | - | ns |
| | High Level Width | t_{WCH} | 0.3 | - | - | |
| DE | Setup Time | t_{DES} | 5 | - | - | ns |
| | Hold time | t_{DEH} | 10 | - | - | |
| | Horizontal Period | t_{HP} | 750 | 800 | 900 | t_{CLK} |
| | Horizontal Valid | t_{HV} | 640 | | | |
| | Horizontal Blank | t_{HBK} | 110 | 160 | 260 | |
| | Vertical Period | t_{VP} | 515 | 525 | 560 | t_{HP} |
| | Vertical Valid | t_{VV} | 480 | | | |
| | Vertical Blank | t_{VBK} | 35 | 45 | 80 | |
| Vertical Frequency | f_V | 55 | 60 | 65 | Hz | |
| DATA | Setup Time | t_{DS} | 4 | - | - | ns |
| | Hold Time | t_{DH} | 8 | - | - | |

Remarks :

*1) High level of logic signal is 80% ◦ Low level of logic signal is 20%

*2) This module is operated by DE only mode

5.2 Timing sequence(Timing chart)

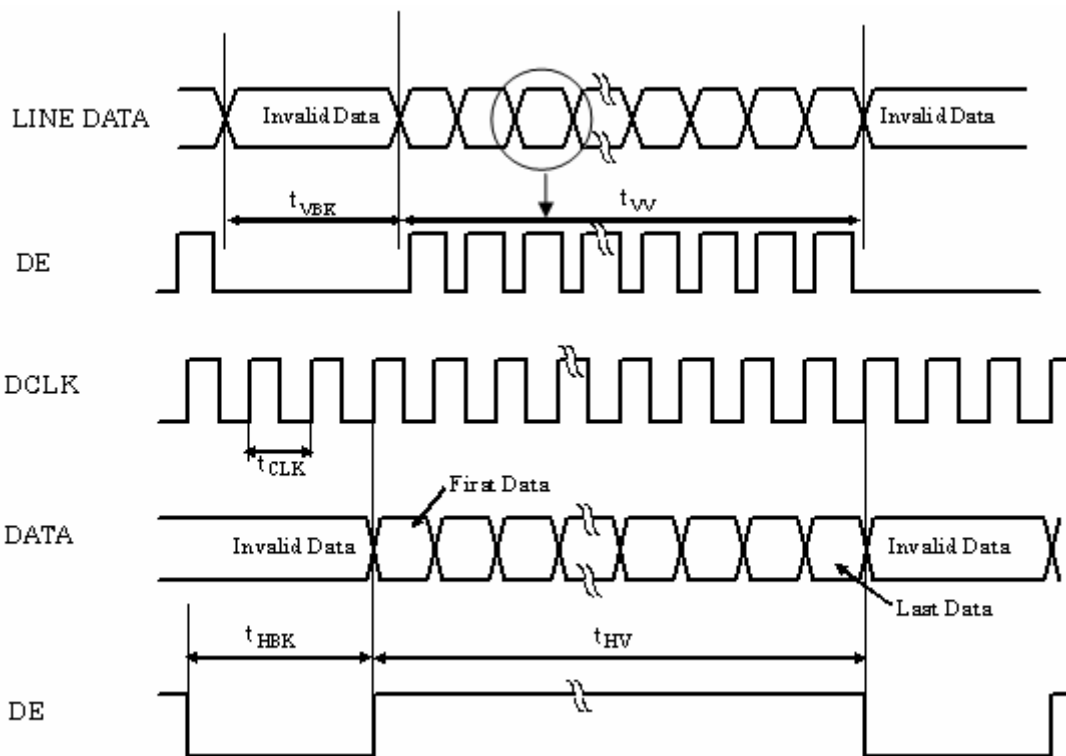
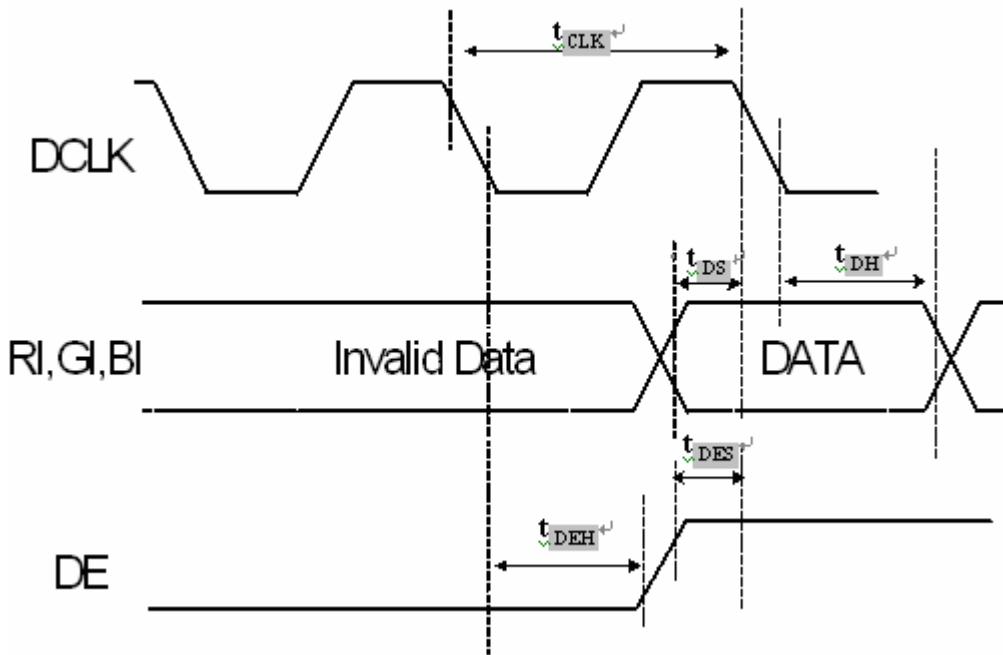

5.3 Color Data Assignment

| COLOR | INPUT | R DATA | | | | | | G DATA | | | | | | B DATA | | | | | |
|-------|-----------|--------|----|----|----|----|-----|--------|----|----|----|----|-----|--------|----|----|----|----|-----|
| | | R5 | R4 | R3 | R2 | R1 | R0 | G5 | G4 | G3 | G2 | G1 | G0 | B5 | B4 | B3 | B2 | B1 | B0 |
| | DATA | MSB | | | | | LSB | MSB | | | | | LSB | MSB | | | | | LSB |
| | BLACK | 0 | 0 | 0 | 0 | 0 | 0 | 0 | 0 | 0 | 0 | 0 | 0 | 0 | 0 | 0 | 0 | 0 | 0 |
| | RED(63) | 1 | 1 | 1 | 1 | 1 | 1 | 0 | 0 | 0 | 0 | 0 | 0 | 0 | 0 | 0 | 0 | 0 | 0 |
| BASIC | GREEN(63) | 0 | 0 | 0 | 0 | 0 | 0 | 1 | 1 | 1 | 1 | 1 | 1 | 0 | 0 | 0 | 0 | 0 | 0 |
| COLOR | BLUE(63) | 0 | 0 | 0 | 0 | 0 | 0 | 0 | 0 | 0 | 0 | 0 | 0 | 1 | 1 | 1 | 1 | 1 | 1 |
| | CYAN | 0 | 0 | 0 | 0 | 0 | 0 | 1 | 1 | 1 | 1 | 1 | 1 | 1 | 1 | 1 | 1 | 1 | 1 |
| | MAGENTA | 1 | 1 | 1 | 1 | 1 | 1 | 0 | 0 | 0 | 0 | 0 | 0 | 1 | 1 | 1 | 1 | 1 | 1 |
| | YELLOW | 1 | 1 | 1 | 1 | 1 | 1 | 1 | 1 | 1 | 1 | 1 | 1 | 0 | 0 | 0 | 0 | 0 | 0 |
| | WHITE | 1 | 1 | 1 | 1 | 1 | 1 | 1 | 1 | 1 | 1 | 1 | 1 | 1 | 1 | 1 | 1 | 1 | 1 |
| | RED(0) | 0 | 0 | 0 | 0 | 0 | 0 | 0 | 0 | 0 | 0 | 0 | 0 | 0 | 0 | 0 | 0 | 0 | 0 |
| | RED(1) | 0 | 0 | 0 | 0 | 0 | 1 | 0 | 0 | 0 | 0 | 0 | 0 | 0 | 0 | 0 | 0 | 0 | 0 |
| | RED(2) | 0 | 0 | 0 | 0 | 1 | 0 | 0 | 0 | 0 | 0 | 0 | 0 | 0 | 0 | 0 | 0 | 0 | 0 |
| RED | | | | | | | | | | | | | | | | | | | |
| | RED(62) | 1 | 1 | 1 | 1 | 1 | 0 | 0 | 0 | 0 | 0 | 0 | 0 | 0 | 0 | 0 | 0 | 0 | 0 |
| | RED(63) | 1 | 1 | 1 | 1 | 1 | 1 | 0 | 0 | 0 | 0 | 0 | 0 | 0 | 0 | 0 | 0 | 0 | 0 |
| | GREEN(0) | 0 | 0 | 0 | 0 | 0 | 0 | 0 | 0 | 0 | 0 | 0 | 0 | 0 | 0 | 0 | 0 | 0 | 0 |
| | GREEN(1) | 0 | 0 | 0 | 0 | 0 | 0 | 0 | 0 | 0 | 0 | 0 | 1 | 0 | 0 | 0 | 0 | 0 | 0 |
| | GREEN(2) | 0 | 0 | 0 | 0 | 0 | 0 | 0 | 0 | 0 | 0 | 1 | 0 | 0 | 0 | 0 | 0 | 0 | 0 |
| GREEN | | | | | | | | | | | | | | | | | | | |
| | GREEN(62) | 0 | 0 | 0 | 0 | 0 | 0 | 1 | 1 | 1 | 1 | 1 | 0 | 0 | 0 | 0 | 0 | 0 | 0 |
| | GREEN(63) | 0 | 0 | 0 | 0 | 0 | 0 | 1 | 1 | 1 | 1 | 1 | 1 | 0 | 0 | 0 | 0 | 0 | 0 |
| | BLUE(0) | 0 | 0 | 0 | 0 | 0 | 0 | 0 | 0 | 0 | 0 | 0 | 0 | 0 | 0 | 0 | 0 | 0 | 0 |
| | BLUE(1) | 0 | 0 | 0 | 0 | 0 | 0 | 0 | 0 | 0 | 0 | 0 | 0 | 0 | 0 | 0 | 0 | 0 | 1 |
| | BLUE(2) | 0 | 0 | 0 | 0 | 0 | 0 | 0 | 0 | 0 | 0 | 0 | 0 | 0 | 0 | 0 | 0 | 1 | 0 |
| BLUE | | | | | | | | | | | | | | | | | | | |
| | BLUE(62) | 0 | 0 | 0 | 0 | 0 | 0 | 0 | 0 | 0 | 0 | 0 | 0 | 1 | 1 | 1 | 1 | 1 | 0 |
| | BLUE(63) | 0 | 0 | 0 | 0 | 0 | 0 | 0 | 0 | 0 | 0 | 0 | 0 | 1 | 1 | 1 | 1 | 1 | 1 |

Remarks :

(1) Definition of Gray Scale

color(n) : n is series of Gray Scale

The more n value is, the bright Gray Scale.

(2)Data:1-High,0-Low

6. CHARACTERISTIC OF TOUCH PANEL

6.1 Basis characteristic

| Item | Standard | Note |
|------------------------------|---|---|
| Operating Voltage | 3V(Min)/5V(Typ)/7V(Max) | DC |
| Surface Treatment | Anti-Glare , Hardness : 2H | |
| Activation Force | < 80gf | Less than 80gf(Typical 25gf) individual with stylus pen (R 0.8mm) or finger (R 8.0mm) |
| Linearity Force | 130 gf | 2 Layer(Thickness :0.7mm) |
| Interface Type | 4 Wire Resistive | |
| Resistance Between Terminals | X(Glass side) : 120~640Ω Y(Film side) : 200~900Ω | At the connector |
| Linearity | X(Glass side) : ≤ 1.5% Y(Film side) : ≤ 1.5% | Testing interval is 2mm with load 80g |
| Insulation Resistance | Min. 20MΩ | At DC 25V |

6.2 Design guideline for Touch-Panel

- The Housing Cushion on touch-panel must be set at outside of T.P's view-area .
- The Cushion material must be elastic material.
- The housing must avoid to touch the T.P
- To combine, the housing should not be stuck on T.P.
- Example of housing design :

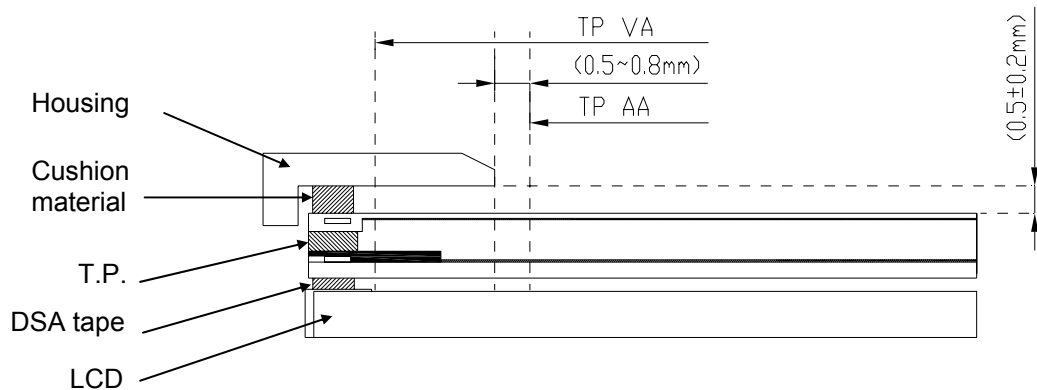

6.3 Circuit Diagram

| PIN No. | Assignment |
|---------|------------|
| 1 | Y1 |
| 2 | X1 |
| 3 | Y2 |
| 4 | X2 |

X: Film electrode
Y: Glass electrode

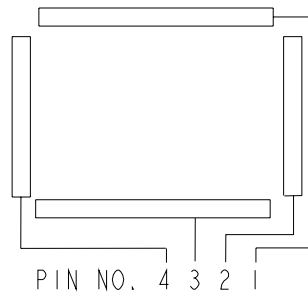

7. BLOCK DIAGRAM

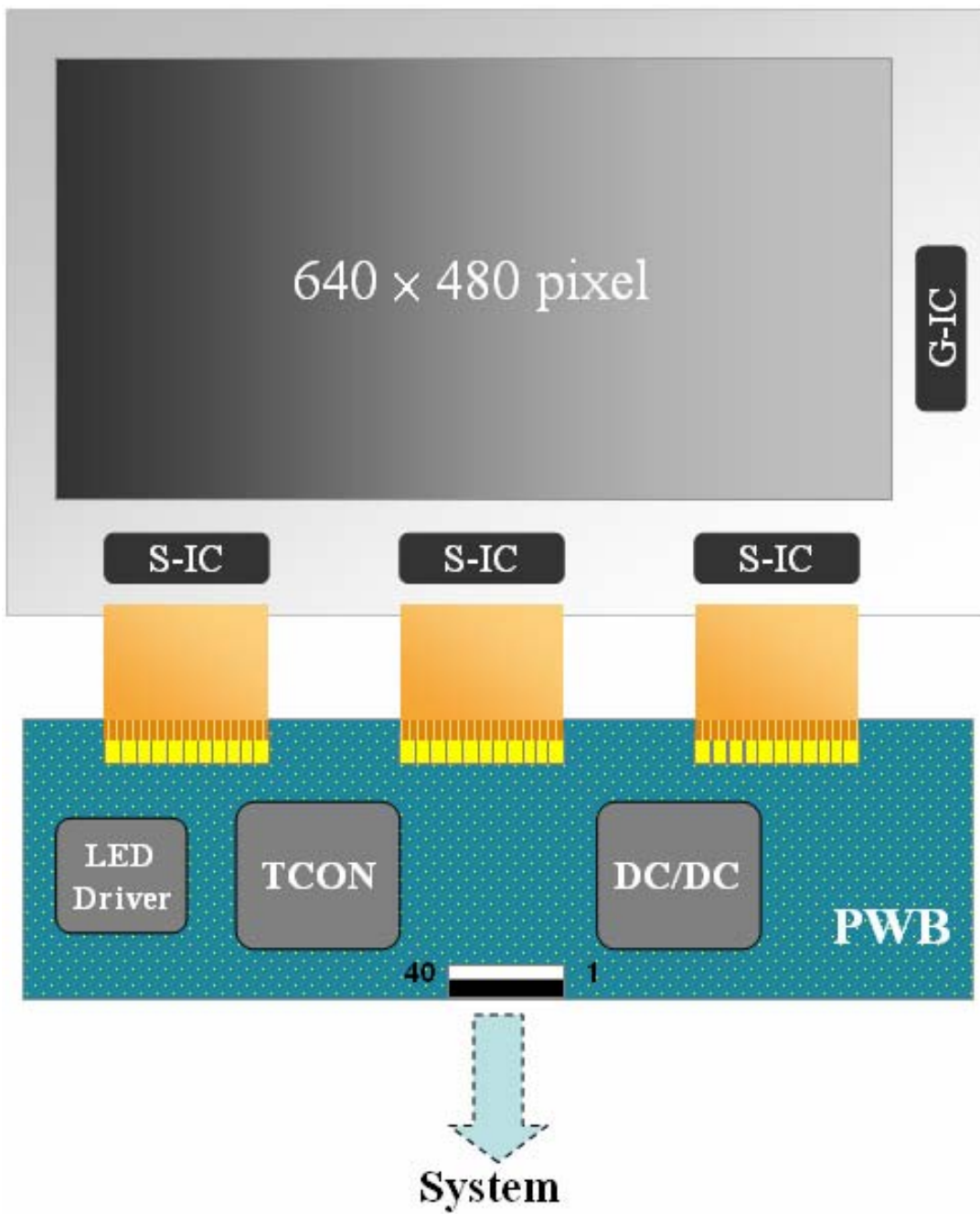

8. MECHANICAL DIMENSION

8.1 Front Side

[Unit : mm]

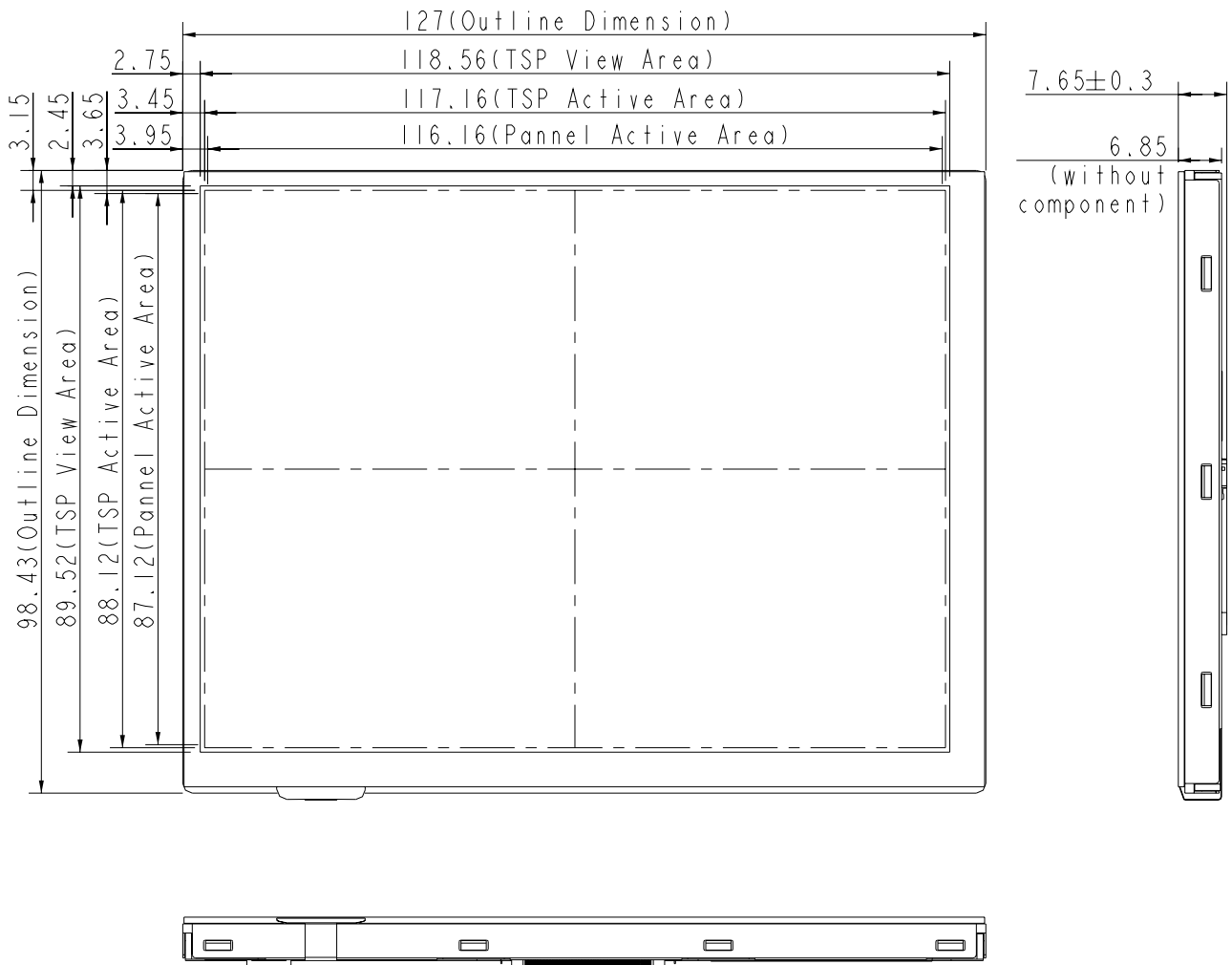

8.2 Rear Side

[Unit : mm]

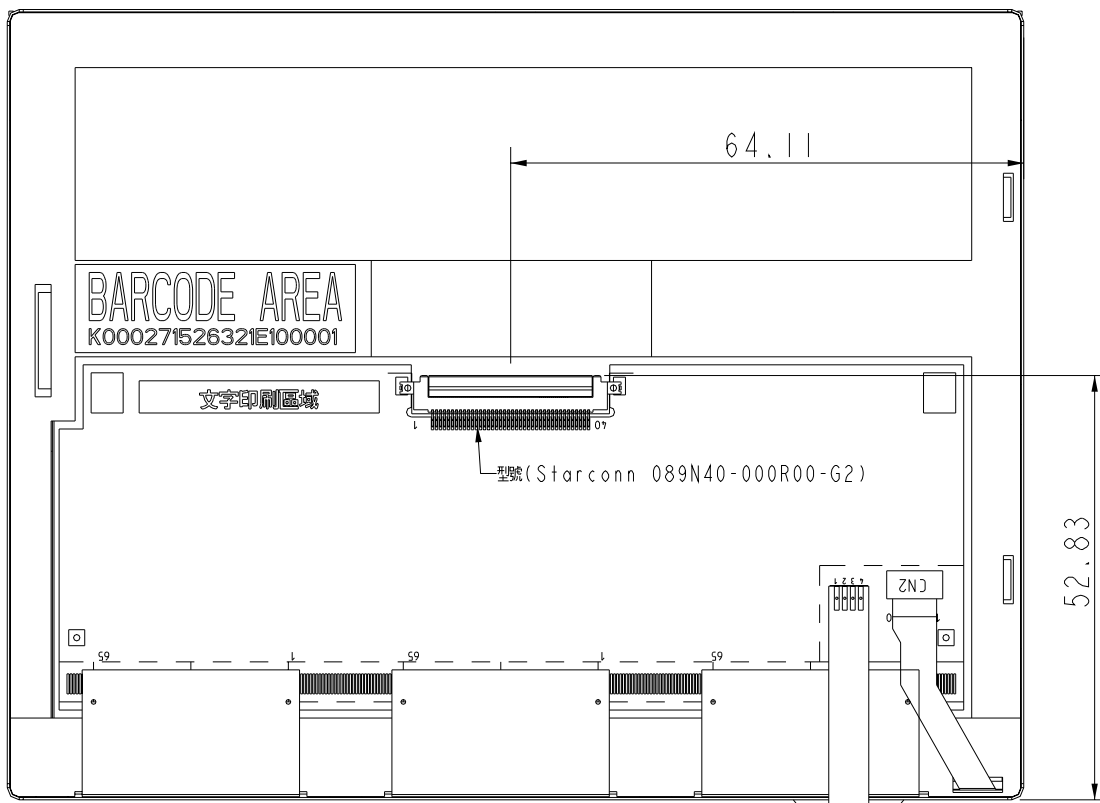

Remark : Un-indication tolerance is ± 0.3 mm

9. OPTICAL CHARACTERISTICS

| ITEM | SYMBOL | CONDITION | MIN. | TYP. | MAX. | UNIT | Remarks | |
|----------------------------------|------------|-----------|-------------------------|----------------|----------------|-------------------|------------|-----------|
| Constrast Ratio | CR | Point-5 | 200 | 300 | -- | -- | *1)*2)*3) | |
| Luminance | Lw | Point-5 | 160 | 180 | -- | cd/m ² | *1)*3) | |
| Luminance Uniformity | ΔL | | 70 | 80 | -- | % | *1)*3) | |
| Response Time (White - Black) | Tr+ Tf | Point-5 | -- | 30 | 50 | ms | *1)*3)*5) | |
| Viewing Angle | Horizontal | ϕ | CR \geq 10 Point-5 | 120 | 140 | -- | $^{\circ}$ | *1)*2)*4) |
| | Vertical | θ | | 80 | 100 | -- | $^{\circ}$ | *1)*2)*4) |
| Color Coordinate | White | Wx Wy | Point-5 | 0.273 0.289 | 0.313 0.329 | 0.353 0.369 | -- | *1)*3) |
| | Red | Rx Ry | | TBD | TBD | TBD | | |
| | Green | Gx Gy | | TBD | TBD | TBD | | |
| | Blue | Bx By | | TBD | TBD | TBD | | |

Remarks :

*1)Measure condition : 25°C \pm 2°C , 60 \pm 10%RH , under10 Lux in the dark room.BM-5A (TOPCON) , viewing angle2° , VCC=3.3V , V_{LED}=5V.

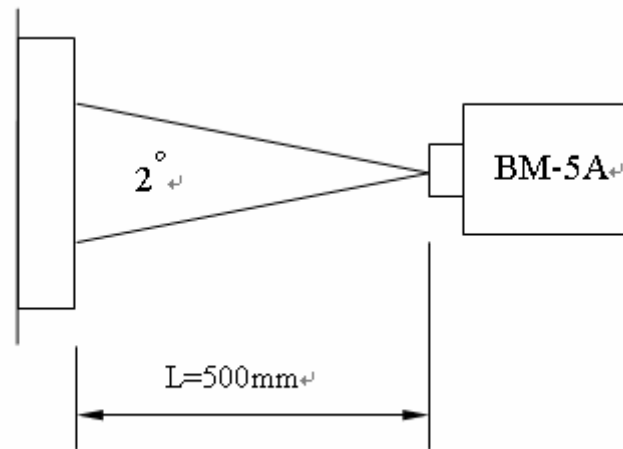

*2) Definition of contrast ratio :

Contrast Ratio (CR)= (White) Luminance of ON \div (Black) Luminance of OFF

*3) Definition of luminance :

Measure white luminance on the point 5 as figure8-1
 Definition of Luminance Uniformity:
 Measure white luminance on the point1~9 as figure8-1
 $\Delta L = [L(\text{MIN})/L(\text{MAX})] \times 100$

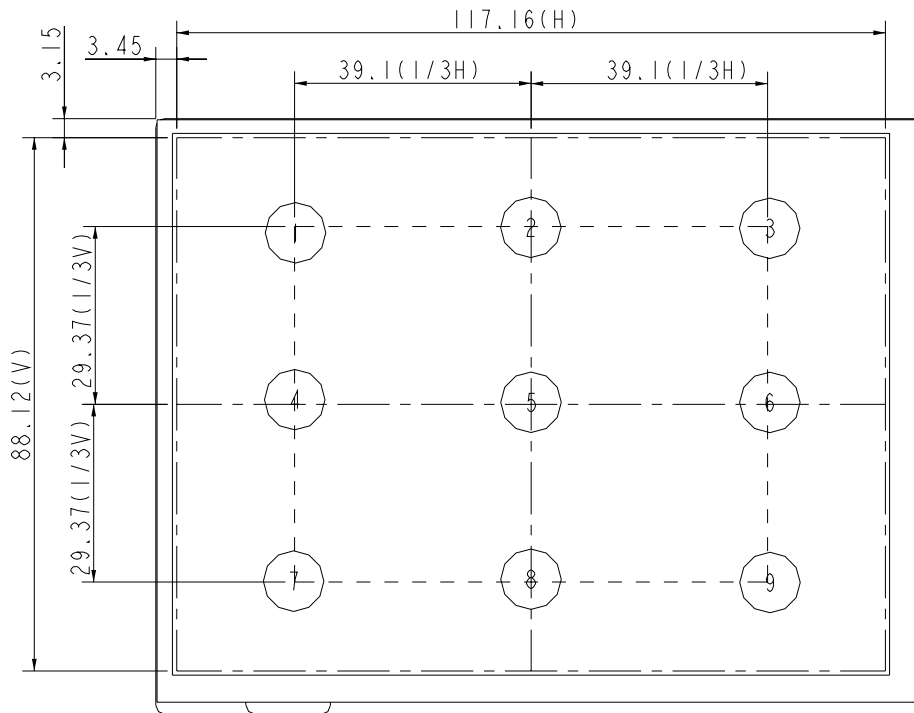

Fig8-1 Measuring point

*4) Definition of Viewing Angle(θ, ψ), refer to Fig8-2 as below :

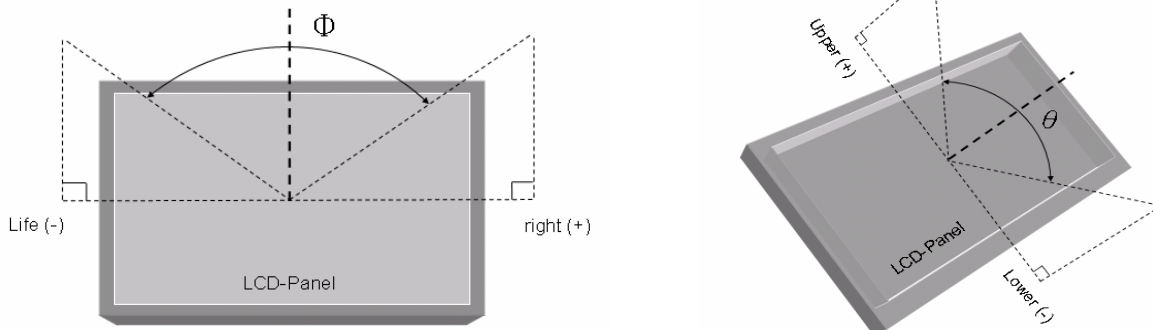

Fig8-2 Definition of Viewing Angle

*5) Definition of Response Time.(White-Black)

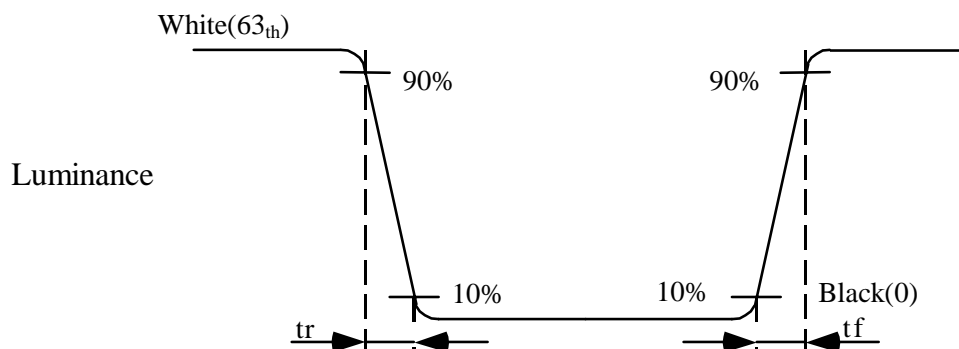

Fig8-3 Definition of Response Time(White-Black)

10. RELIABILITY TEST

10-1. Temperature and humidity

| TEST ITEMS | CONDITIONS |
|--|--|
| High Temperature Operation | 85°C , 240H |
| High Temperature Storage | 95°C , 240H |
| High Temperature High Humidity Operation | 60°C , 90%RH , 240H |
| Low Temperature Operation | -30°C , 240H, Backlight unit always turn on |
| Low Temperature Storage | -40°C , 240H |
| Thermal Shock | -30°C (0.5Hr) ~ 85°C (0.5Hr) 200 cycles |

10-2. Shock and Vibration

| TEST ITEMS | CONDITIONS |
|------------------------------|---|
| Shock (Non-operation) | <ul style="list-style-type: none">● Shock level:980m/s²(equal to 100G)● Waveform:half sinusoidal wave,6ms.● Number of shocks:one shock input in each direction of three mutually perpendicular axes for a total of three shock inputs. |
| Vibration (Non-operation) | <ul style="list-style-type: none">● Frequency range:8~33.3Hz● Stoke:1.3mm● Vibration:sinusodial wave,perpendicularaxis(both x,y,z axis:2Hrs).● Sweep:2.9G,33.3Hz-400Hz● Cycle:15min |

10-3. Judgment standard

The Judgment of the above test should be made as follow:

Pass:Normal display image with no obvious non-uniformity and no line defect.Partial trasformation of the module parts should be ignored.

Fail:No display image,obvious non-uniformity,or line defect.