



OSD Displays

4111 Metric Drive, Suite 5
Winter Park, FL 32792
Phone: 407-629-0500
Fax: 407-645-5376
sales@osddisplays.com
www.osddisplays.com

Customer: _____
Model Number: OSD0760WVGA-T
Specification Number: _____
Date: 3/13/2009
Version: 1.0 (preliminary)

For Customer's Acceptance

Approved by	Comments

Approved by	Reviewed by	Prepared by



Reversion History

Version	Date	Page	Description
Ver.1.0	2009/03/13	All	Preliminary specification was first issued
		4	Change DC Characteristic—OLED description
		6	Modify Note (4) Drawing
		8	Modify Electro-Optical Characteristic
		8	Modify (1) Test condition Drawing
		9	Modify (3) Viewing angle test condition Drawing
		10	Modify System Diagram Drawing
		23	Add Panel ID Label Naming Rule description
		25	Add Warranty description

1. Purpose:

This documentation defines general product specification for OLED module supplied by OSD. The information described in this technical specification is tentative. Please Contact OSD’s representative while your product is modified.

2. General Description:

- Driving Mode: Active Matrix
- Color Mode: Full Color (16.7M color)
- Support 3-wire SPI command setting
- Interface: LVDS interface and DE only mode.
- Auto-current limit function (ACL) for power saving mode.
- Application: Portable DVD, PMP, GPS, Photo Frame etc.
- RoHS Compatible

3. Mechanical Data:

No.	Items	Specification	Unit
1	Diagonal Size	7.6	Inch
2	Resolution	800 RGB x 480	
3	Pixel Pitch	207 x 207	um
4	Active Area	165.60 x 99.36	mm
5	Outline Area	177.30 x 118.32	mm
6	Thickness	Max 5.4	mm
7	Weight	150	g

4. Absolute Maximum ratings:

Absolute ratings of environment :

Item	Symbol	Value		Unit	Note
		Min.	Max.		
Storage Temperature	T _{ST}	-40	+80	°C	(1)
Operating Ambient Temperature	T _{OP}	-20	+60	°C	(2)

Note (1) The storage duration for both critical temperature (-40 & 80°C) meet reliability test criteria.

(2) The operating duration for both critical temperature (-20 & 60°C) meet reliability test criteria.

5. Electrical Characteristic:

5.1 DC Characteristic—module

Parameter	Symbol	Min.	Typ.	Max.	Unit	Note
Power Supply Voltage	VCI	4.5	5	5.5	V	-
Permissive Ripple Voltage	V _{PR}			100	mV	
Rush Current	I _{RUSH}			1.84	A	(1)
Initial Stage Current	I _S		0.39		A	(1)

5.2 DC Characteristic—OLED

Parameter	Symbol	Min.	Typ.	Max.	Unit	Note
Positive power	VDD	5.15	5.2	5.25	V	-
Negative power	VSS	-4.9	-4.8	-4.7	V	

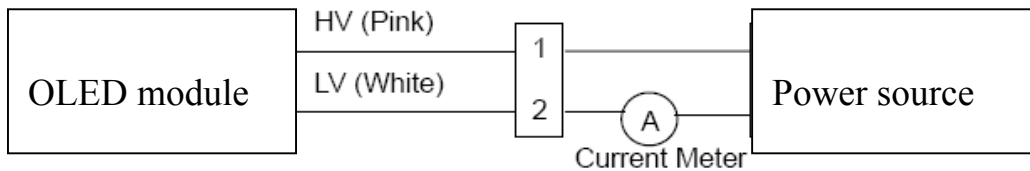

Note (1):

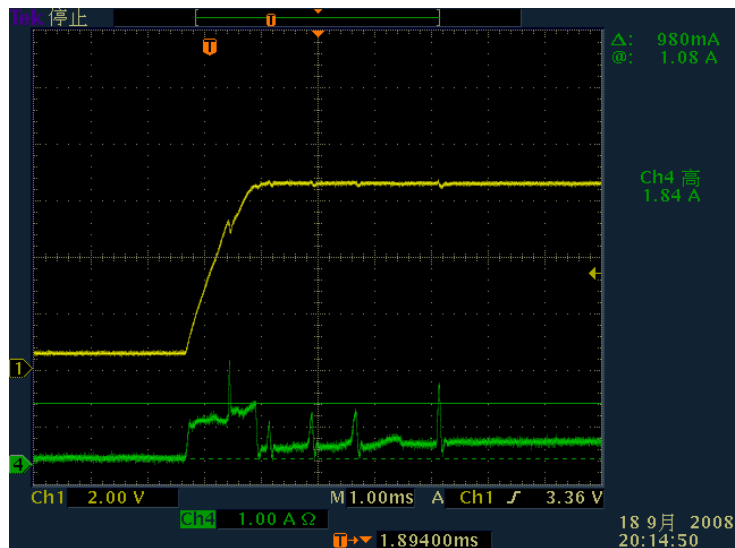

Yellow Line: VCI

Green Line: Current of VCI

Rush Current: the peak current after turn on the power.

Initial Stage Current: normal operation current.

5.3 AC Characteristic—LVDS

Parameter	Symbol	Min.	Typ.	Max.	Unit	Note
LVDS Differential Input High Threshold	$V_{TH(LVDS)}$			+100	mV	(2)
LVDS Differential Input Low Threshold	$V_{TL(LVDS)}$	-100			mV	(2)
LVDS Common Mode Voltage	V_{CM}	1.125	1.2	1.375	V	(2)
OLED Diode Refer Voltage	$ V_{ID} $	100		600	mV	(2)
Terminating Resistor	R_T		100		Ohm	
DCLK frequency	F_{CPH}	27.08	30	-	MHz	(3)
DCLK period	T_{CPH}	-	33.3	36.93	ns	(3)
DCLK pulse duty	T_{CWH}	-	50	-	%	(3)
DE pulse width	T_{EP}	-	800	-	T_{CPH}	(3)
HSYNC pulse width	T_{WH}	10	40	-	T_{CPH}	(3)
HSYNC-first horizontal data time	T_{HBP}	100	198	-	T_{CPH}	(3)
HSYNC front porch	T_{HFP}	10	10	-	T_{CPH}	(3)
HSYNC period	T_H	910	1008	-	T_{CPH}	(3)
VSYNC pulse width	T_{WV}	3	3	-	T_H	(3)
VSYNC-1 st Data input (DE) time	T_{VBP}	10	10	-	T_H	(3)
VSYNC front porch	T_{VFP}	6	6	-	T_H	(3)
VSYNC period	T_V	496	496	-	T_H	(3)

Note (2) The parameters of LVDS signals are defined as the following figures.

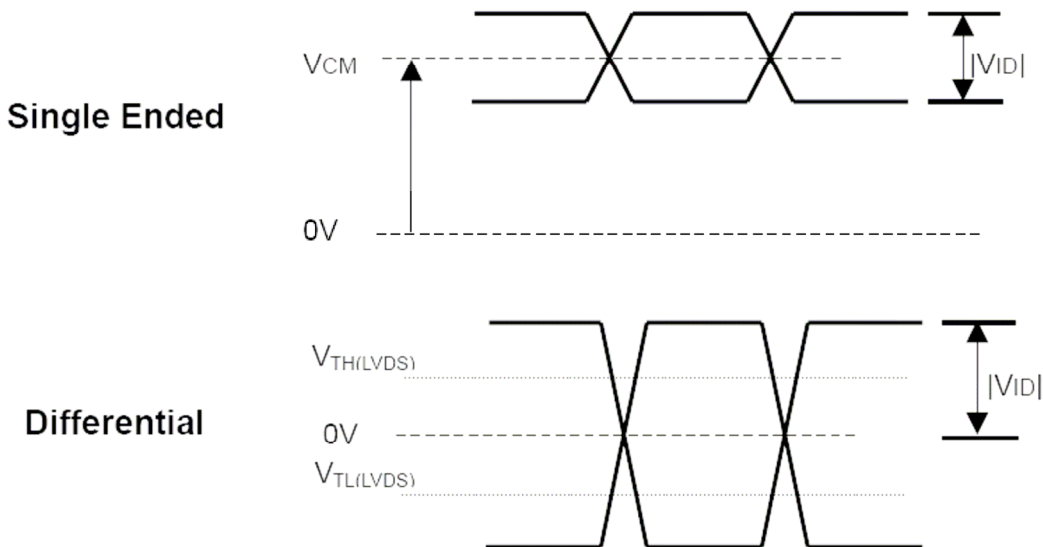

Note (3) The timing specification of LVDS signals are defined as the following figures.

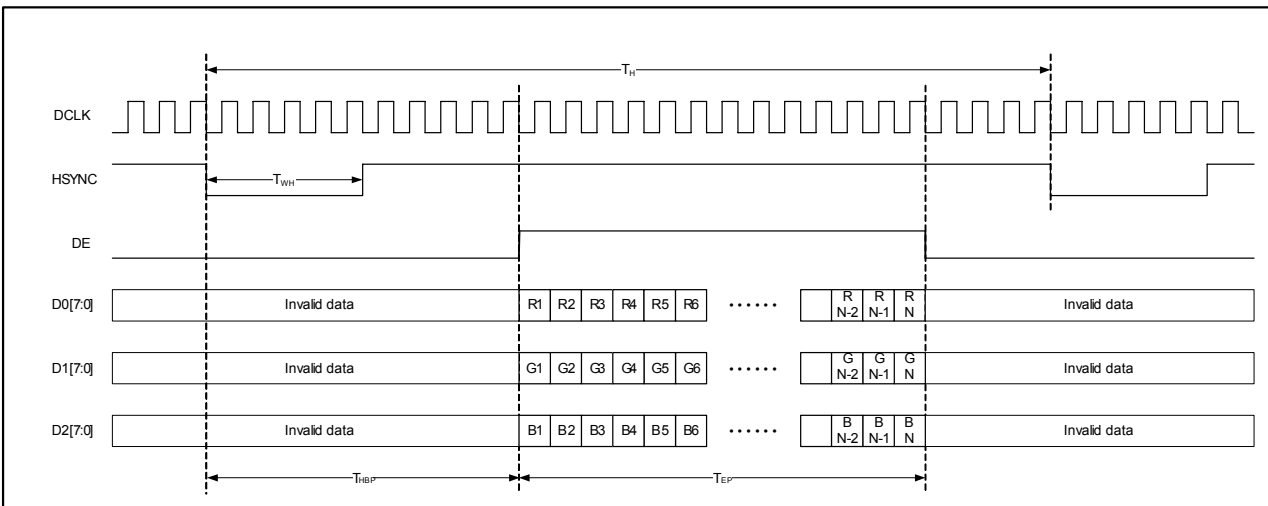
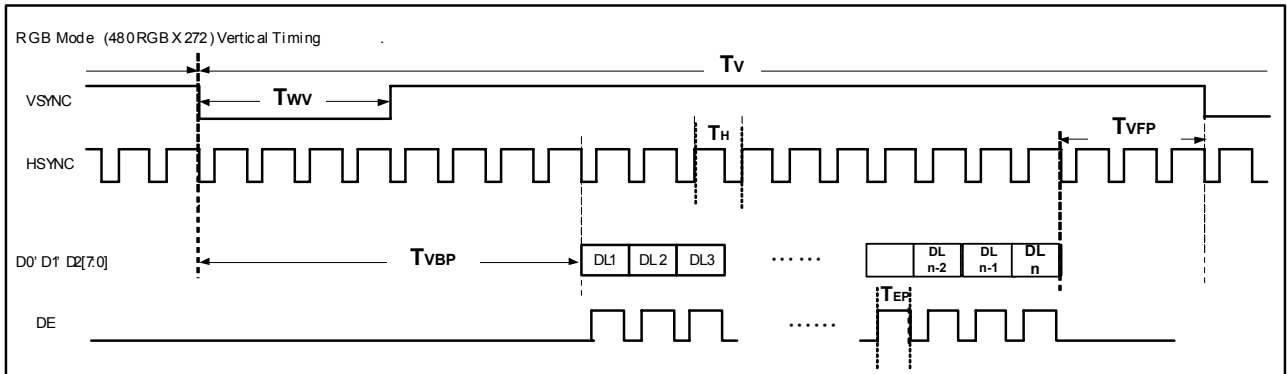

5.4 AC Characteristic—SPI

Parameter	Symbol	Min.	Typ.	Max.	Unit	Note
Time from NCS to SCL	Ts0	40			ns	
Time from SCL to NCS	Th0	60			ns	
SCL low time	Twih		Tcyc/2		ns	
SCL high time	Twil		Tcyc/2		ns	
Setup time of SDA	Tsl	40			ns	
Hold time of SDA	Thl	40			ns	
NCS high pulse width	Tw2	500			ns	
Serial clock cycle time	Tcyc	100	500		ns	
Time from NCS to SCL	Ts0	40			ns	
Time from SCL to NCS	Th0	60			ns	
SCL low time	Twih		Tcyc/2		ns	

5.5 DC Characteristic—SPI

Parameter	Symbol	Min.	Typ.	Max.	Unit	Note
Logic High Input voltage	VIH	0.8*3.3		3.3	V	
Logic Low Input voltage	VIL	0		0.2*3.3	V	

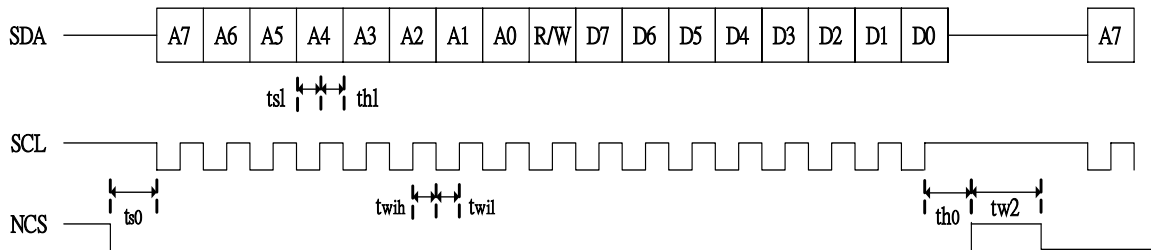

6. Electro-Optical Characteristic:

Items	Symbol	Min	Typ.	Max	Unit	Remark
Luminance	L	185	200	215	Cd/m ²	(1)(5)
Power Consumption	Pon			8	W	30% pixels on (1)
				17.1	W	100% pixels on (1)
Maximum Current	Icc			1300	mA	(1)
Response Time	Tres			50	uS	(2)
Color Gamma	NTSC		70		%	(1)
CIE _x (White)	W _x	0.26	0.28	0.30	-	(5)
CIE _y (White)	W _y	0.28	0.30	0.32	-	(5)
Viewing Angle	VA	170			Degree	(3)
Contrast	CR	30000:1				(4)
Operation Lifetime	L _{Top}	30000			Hrs	(1)(6)
Surface Reflectance				3	%	At 60 lux
Color Temperature			9500		K	
Uniformity		75	80		%	(7)

Note:

Measuring surrounding: dark room

Surrounding temperature: 25°C

(1) Test condition:

We measure the center area of the panel with full white pattern, and fix full white 200nits to adjust gamma code.

VDD= +5.2V, VSS= -4.8V

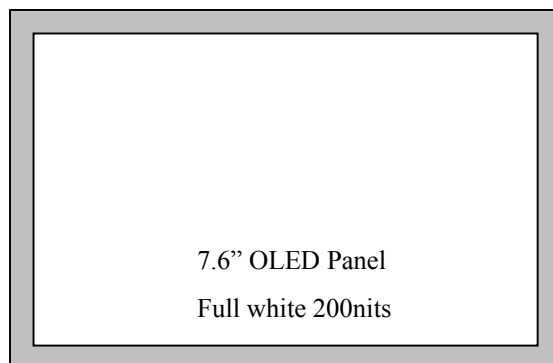

(2) Response Time test condition

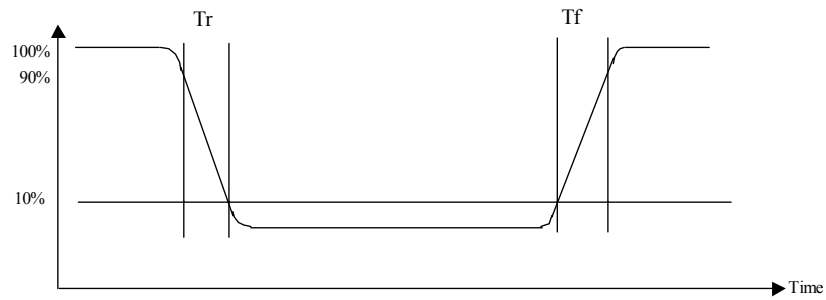

(3) Viewing angle test condition:

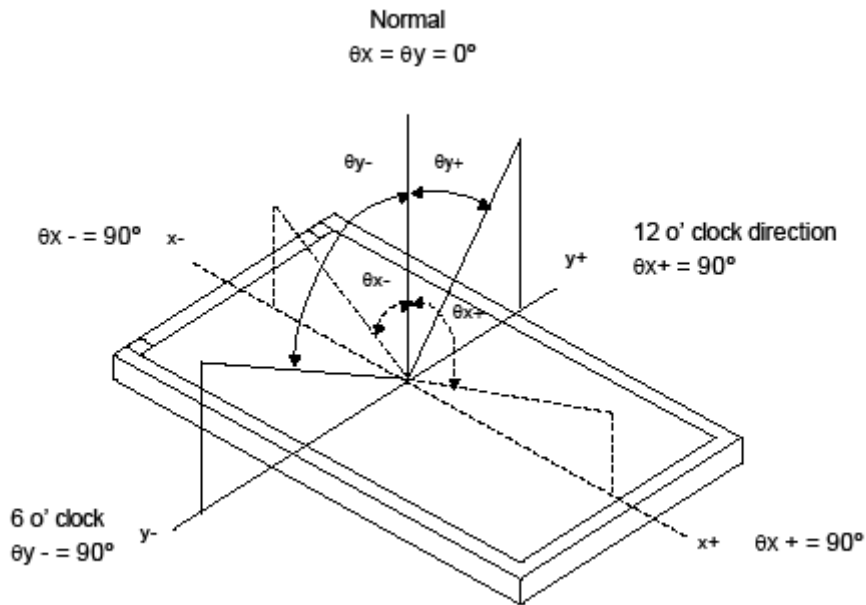

(4) Contrast

$$CR = \frac{\text{Luminance with all pixels white}}{\text{Luminance with all pixels black}}$$

(5) Optical tester: CA210 (In the display center)

(6) Operation Life Time is defined when the luminance decay to less than 50% of the initial luminance during the average operation. The Luminance of the average operation is defined picture changing 30% power consumption at full on 200nits.

(7) Follow VESA rule.

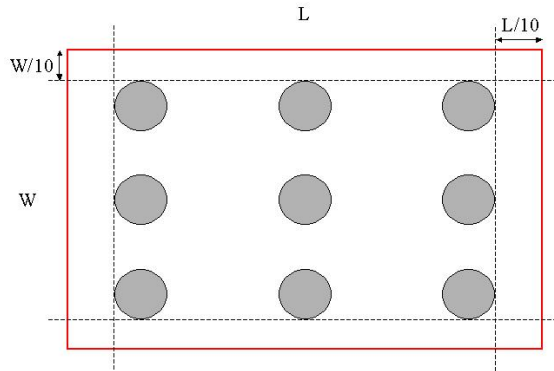

7. System Diagram:

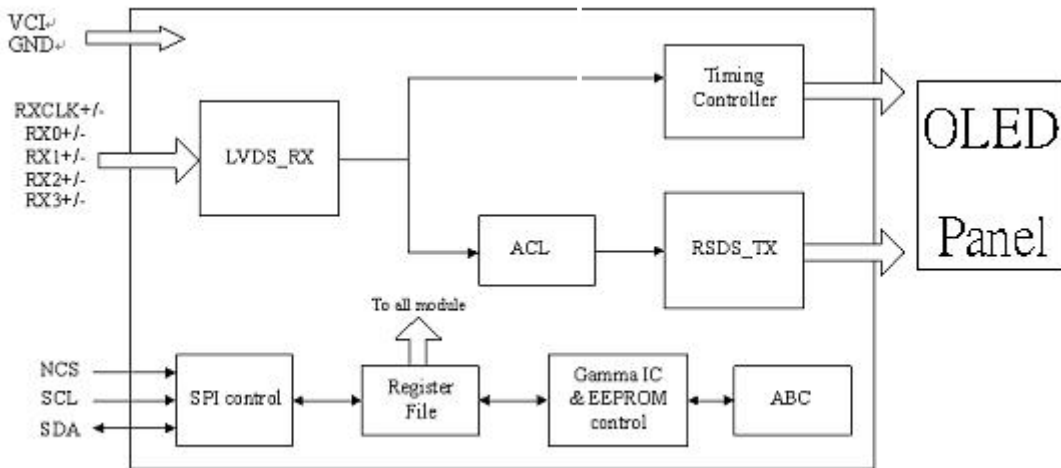

8. Input Terminal Pin Assignment:

8.1 OLED module

PIN	Symbol	I/O	Description	Remarks
1	VCI	P	Power supply 5V (typical)	5V
2	GND	P	Ground	Ground
3	NC	-	Not connect	Open
4	NC	-	Not connect	Open
5	NC	-	Not connect	Open
6	NC	-	Not connect	Open
7	NC	-	Not connect	Open
8	RX0-	I	Negative LVDS differential data input, Channel 0	RX0-
9	RX0+	I	Positive LVDS differential data input, Channel 0	RX0+
10	GND	P	Ground	Ground
11	RX1-	I	Negative LVDS differential data input, Channel 1	RX1-
12	RX1+	I	Positive LVDS differential data input, Channel 1	RX1+
13	GND	P	Ground	Ground
14	RX2-	I	Negative LVDS differential data input, Channel 2	RX2-
15	RX2+	I	Positive LVDS differential data input, Channel 2	RX2+
16	GND	P	Ground	Ground
17	RXCLK-	I	Negative LVDS differential clock input	RXCLK-
18	RXCLK+	I	Positive LVDS differential clock input	RXCLK+
19	GND	P	Ground	Ground
20	RX3-	I	Negative LVDS differential data input, Channel 3	RX3-
21	RX3+	I	Positive LVDS differential data input, Channel 3	RX3+
22	GND	P	Ground	Ground
23	GND	P	Ground	Ground
24	GND	P	Ground	Ground
25	GND	P	Ground	Ground
26	SCL	I	Serial interface clock pin.	SCL
27	SDA	I/O	Serial interface data input and output line	SDA
28	NCS	I	Serial interface chip enable line	NCS
29	VCI	P	Power supply 5V (typical)	5V
30	VCI	P	Power supply 5V (typical)	5V

Note: (1) Connector Part No : FI-XPB30SL-HF10 or equivalent.

Note: (2) User's connector Part No : P2407P30 or equivalent.

8.2 OLED unit

PIN	Symbol	I/O	Description	Remarks
1	VDD	P	Positive power	Pink
2	VSS	P	Negative power	White

8.3 Timing Diagram of LVDS input signal

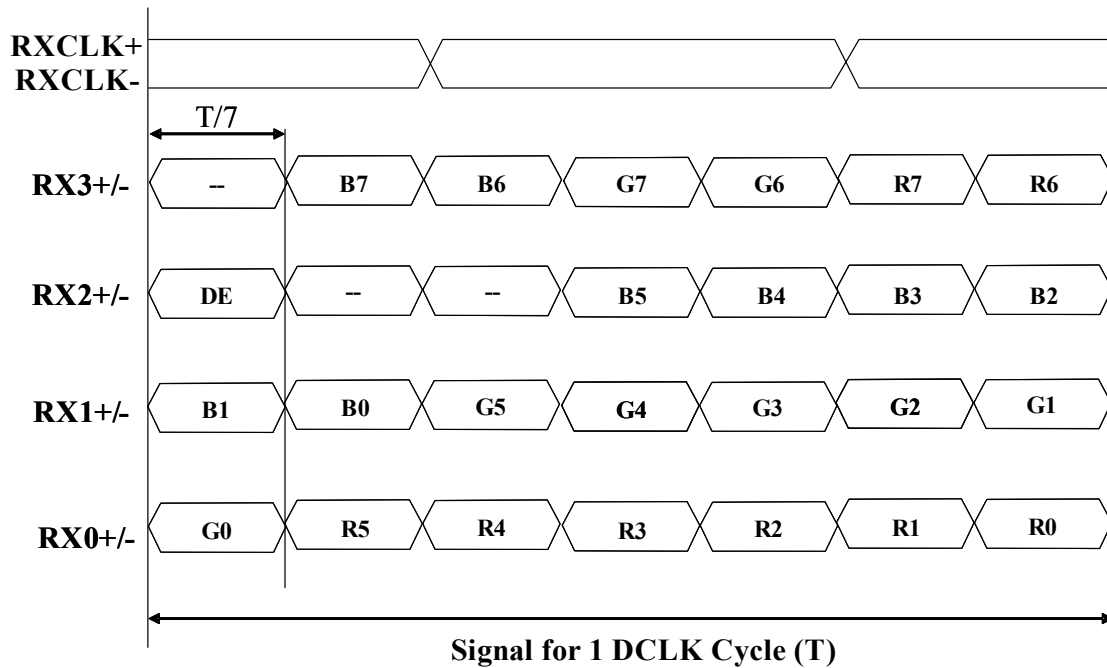

8.4 Register description:

NAME	ADDR	R/W	Description
TCONCTL5	05h	R/W	[7:0] VBP: Vertical valid data start time select. 0x00: 3 HSYNC 0x01: 4 HSYNC 0x07: 10 HSYNC (default) 0xFE: 257 HSYNC 0xFF: 258 HSYNC Default: 07h
TCONCTL6	06h	R/W	[7:0] VFP: 0x00: 5HSYNC (default) 0x01: 6HSYNC

			0xFE: 259 HSYNC 0xFF: 260 HSYNC Default: 00h
TCONCTL7	07h	R/W	[7:0] HBP: Horizontal valid data start time select. 0x00: 3 DCLK 0x01: 4 DCLK 0x11: 20 DCLK (default) 0xFE: 257 DCLK 0xFF: 258 DCLK Default: 11h
TCONCTL8	08h	R/W	[7:0] HFP: 0x00: 0 DCLK 0x01: 1 DCLK 0x0A: 10 DCLK (default) 0xFE: 254 DCLK 0xFF: 255 DCLK Default: 0Ah
TCONCTL13	0Dh	R/W	[7] PAT_SELEN: built-in pattern enable 0: disable 1: enable [6:0] PAT_SEL: built-in pattern select Default: 00h
TCONCTL14	0Eh	R/W	[5:0] R_CONSTRA: R constraint 0x00: R data x 0 0x01: R data x 1/32 0x20: R data x 32/32 0x3F: R data x 63/32 Default: 20h
TCONCTL15	0Fh	R/W	[5:0] G_CONSTRA: G constraint

			<p>0x00: G data x 0 0x01: G data x 1/32 0x20: G data x 32/32 0x3F: G data x 63/32</p> <p>Default: 20h</p>
TCONCTL16	10h	R/W	<p>[5:0] B_CONSTR: B constraint 0x00: B data x 0 0x01: B data x 1/32 0x20: B data x 32/32 0x3F: B data x 63/32</p> <p>Default: 20h</p>
TCONCTL17	11h	R/W	<p>[5:0] RGB_CONSTR: RGB constraint 0x00: RGB data x 0 0x01: RGB data x 1/32 0x20: RGB data x 32/32 0x3F: RGB data x 63/32</p> <p>Default: 20h</p>
TCONCTL18	12h	R/W	<p>[7:0] BRIGHT: RGB brightness 0x00: RGB data - 128 0x01: RGB data - 127 0x80: RGB data + 0 0x81: RGB data + 1 0xFF: RGB data + 127</p> <p>Default: 80h</p>
ACLCTL1	1Fh	R/W	<p>[7:1] In-house command. [0] ACLEN: 0: disable ACL function</p>

			<p>1: enable ACL function</p> <p>Default: 82h</p>
SERCTL1	57h	R/W	<p>[6:0] CNTR: GSCL frequency setting parameter GSCL frequency = DCLK / ((CNTR+1) x2) Ex. 24.7Mhz/((31+1) x2) = 24.7Mhz/64 = 386Khz</p> <p>Default: 1Fh</p>
GAMCTL1	58h	R/W	<p>[3:0] GAM_DLY: GSDA delay cycle from GSCL</p> <p>Default: 04h</p>
GAMCTL2	59h	R/W	<p>[7] BKSEL: select gamma IC memory bank 0: select bank 0 1: select bank 1</p> <p>[6] A0 0: select gamma IC 1 1: select gamma IC 2</p> <p>[5:0] STRADR: gamma output voltage selected address, when BUR_WRT (5Bh bit 4) is 1, STRADR represents gamma output voltage start address, other mode represent the selected address of gamma IC</p> <p>Default: 00h</p>
GAMCTL3	5Ah	R/W	<p>[7] GI2CBUSY (read only) : any action of gamma IC and EEPROM must check this bit 0: I2C bus not busy 1: I2C bus busy</p> <p>[5:0] ENDADR: this is useful only at BUR_WRT (5Bh bit 4) is 1, and represents the gamma output voltage end address</p> <p>Default: 17h</p>
GAMCTL4	5Bh	WC	<p>[6] GEN_RST: reset gamma IC [5] SIN_WRT: single write gamma DAC register [4] BUR_WRT: burst write gamma DAC register [3] WRT_MEM: single write gamma IC OTP [2] SIN_READ: single read gamma DAC register [1] GEN_ACQ: general acquire gamma IC OTP to gamma DAC output</p>

			[0] SIN_ACQ: single acquire gamma IC OTP to gamma DAC output Default: 00h
GAMCTL5	5Ch	R	[1:0] RDDATA [9:8]: high byte of read DAC register from gamma IC
GAMCTL 6	5Dh	R	[7:0] RDDATA [7:0]: low byte of read DAC register from gamma IC
EEPROM1	5Eh	R/W	[6:4] BANKSEL: select EEPROM read/write bank 000: write 5Fh ~ 86h to EEPROM bank 0 or read EEPROM bank 0 to 5Fh ~ 86h 001: write 5Fh ~ 86h to EEPROM bank 1 or read EEPROM bank 1 to 5Fh ~ 86h 010: write 5Fh ~ 86h to EEPROM bank 2 or read EEPROM bank 2 to 5Fh ~ 86h 011: write 5Fh ~ 86h to EEPROM bank 3 or read EEPROM bank 3 to 5Fh ~ 86h 1xx: write 00h ~ 5Eh to EEPROM bank4 or read EEPROM bank4 to 00h ~ 5Eh [1] EEPROM_WR (write & clear): EEPROM write [0] EEPROM_RD (write & clear): EEPROM read Default: 40h
RGAMMA01	5Fh	R/W	[7:6] DAC4 [9:8]: R_GAMMA30 high byte [5:4] DAC3 [9:8]: R_GAMMA15 high byte [3:2] DAC2 [9:8]: R_GAMMA5 high byte [1:0] DAC1 [9:8]: R_GAMMA0 high byte
RGAMMA02	60h	R/W	[7:0] DAC1 [7:0]: R_GAMMA0 low byte
RGAMMA03	61h	R/W	[7:0] DAC2 [7:0]: R_GAMMA5 low byte
RGAMMA04	62h	R/W	[7:0] DAC3 [7:0]: R_GAMMA15 low byte
RGAMMA05	63h	R/W	[7:0] DAC4 [7:0]: R_GAMMA30 low byte
RGAMMA06	64h	R/W	[7:6] DAC8 [9:8]: R_GAMMA255 high byte

			[5:4] DAC7 [9:8]: R_GAMMA168 high byte [3:2] DAC6 [9:8]: R_GAMMA84 high byte [1:0] DAC5 [9:8]: R_GAMMA50 high byte
RGAMMA07	65h	R/W	[7:0] DAC5 [7:0]: R_GAMMA50 low byte
RGAMMA08	66h	R/W	[7:0] DAC6 [7:0]: R_GAMMA84 low byte
RGAMMA09	67h	R/W	[7:0] DAC7 [7:0]: R_GAMMA168 low byte
RGAMMA10	68h	R/W	[7:0] DAC8 [7:0]: R_GAMMA255 low byte
GGAMMA01	69h	R/W	[7:6] DAC12 [9:8]: G_GAMMA30 high byte [5:4] DAC11 [9:8]: G_GAMMA15 high byte [3:2] DAC10 [9:8]: G_GAMMA5 high byte [1:0] DAC9 [9:8]: G_GAMMA0 high byte
GGAMMA02	6Ah	R/W	[7:0] DAC9 [7:0]: G_GAMMA0 low byte
GGAMMA03	6Bh	R/W	[7:0] DAC10 [7:0]: G_GAMMA5 low byte
GGAMMA04	6Ch	R/W	[7:0] DAC11 [7:0]: G_GAMMA15 low byte
GGAMMA05	6Dh	R/W	[7:0] DAC12 [7:0]: G_GAMMA30 low byte
GGAMMA06	6Eh	R/W	[7:6] DAC16 [9:8]: G_GAMMA255 high byte [5:4] DAC15 [9:8]: G_GAMMA168 high byte [3:2] DAC14 [9:8]: G_GAMMA84 high byte [1:0] DAC13 [9:8]: G_GAMMA50 high byte
GGAMMA07	6Fh	R/W	[7:0] DAC13 [7:0]: G_GAMMA50 low byte
GGAMMA08	70h	R/W	[7:0] DAC14 [7:0]: G_GAMMA84 low byte
GGAMMA09	71h	R/W	[7:0] DAC15 [7:0]: G_GAMMA168 low byte
GGAMMA10	72h	R/W	[7:0] DAC16 [7:0]: G_GAMMA255 low byte
BGAMMA01	73h	R/W	[7:6] DAC20 [9:8]: B_GAMMA30 high byte

			[5:4] DAC19 [9:8]: B_GAMMA15 high byte [3:2] DAC18 [9:8]: B_GAMMA5 high byte [1:0] DAC17 [9:8]: B_GAMMA0 high byte
BGAMMA02	74h	R/W	[7:0] DAC17 [7:0]: B_GAMMA0 low byte
BGAMMA03	75h	R/W	[7:0] DAC18 [7:0]: B_GAMMA5 low byte
BGAMMA04	76h	R/W	[7:0] DAC19 [7:0]: B_GAMMA15 low byte
BGAMMA05	77h	R/W	[7:0] DAC20 [7:0]: B_GAMMA30 low byte
BGAMMA06	78h	R/W	[7:6] VCOM2 [9:8]: B_GAMMA255 high byte [5:4] VCOM1 [9:8]: B_GAMMA168 high byte [3:2] DAC22 [9:8]: B_GAMMA84 high byte [1:0] DAC21 [9:8]: B_GAMMA50 high byte
BGAMMA07	79h	R/W	[7:0] DAC21 [7:0]: B_GAMMA50 low byte
BGAMMA08	7Ah	R/W	[7:0] DAC22 [7:0]: B_GAMMA84 low byte
BGAMMA09	7Bh	R/W	[7:0] VCOM1 [7:0]: B_GAMMA168 low byte
BGAMMA10	7Ch	R/W	[7:0] VCOM2 [7:0]: B_GAMMA255 low byte
EEPROM2	FFh	R/W	[0] EE_RDEN: this bit have to use with EEPROM_WR (5Eh bit1), when this bit set high first and write EEPROM_WR = 1, the register 00h ~ 5Eh default value are download by EEPROM after the system power on

9. Power sequence.

9.1 Power on sequence

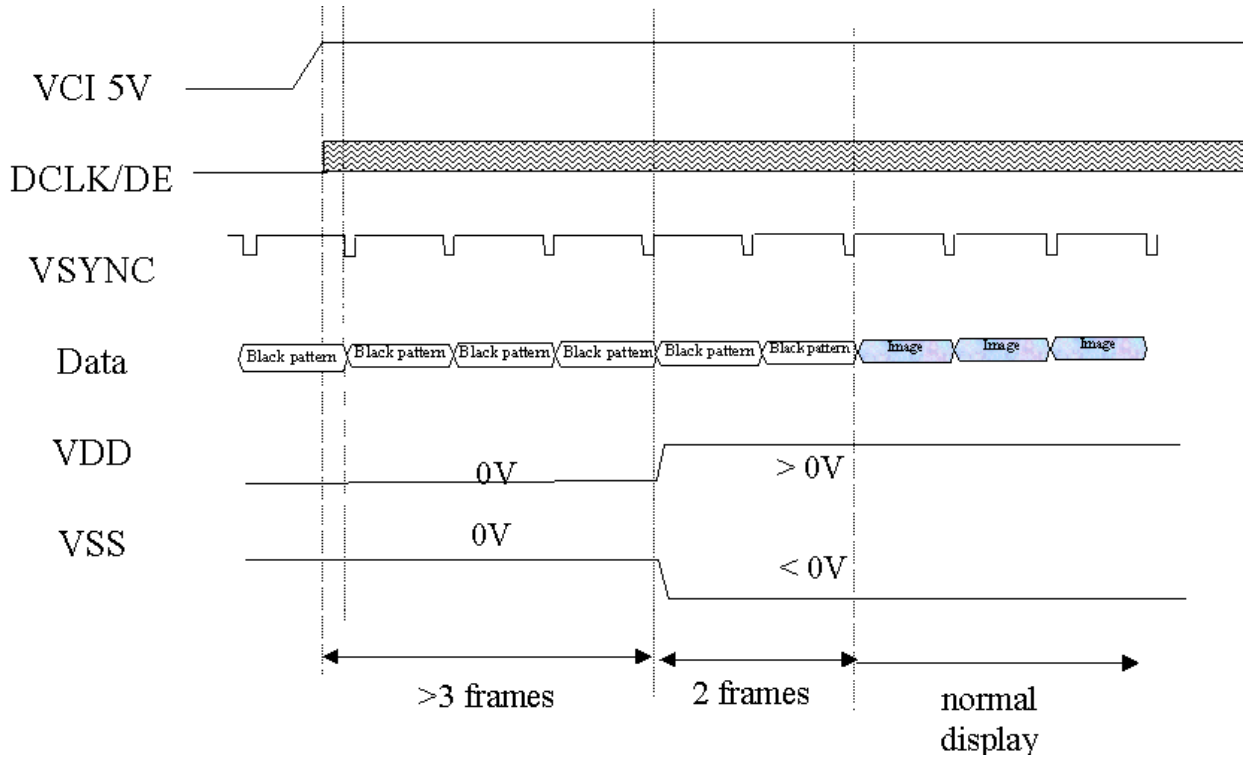

9.2 Power off sequence

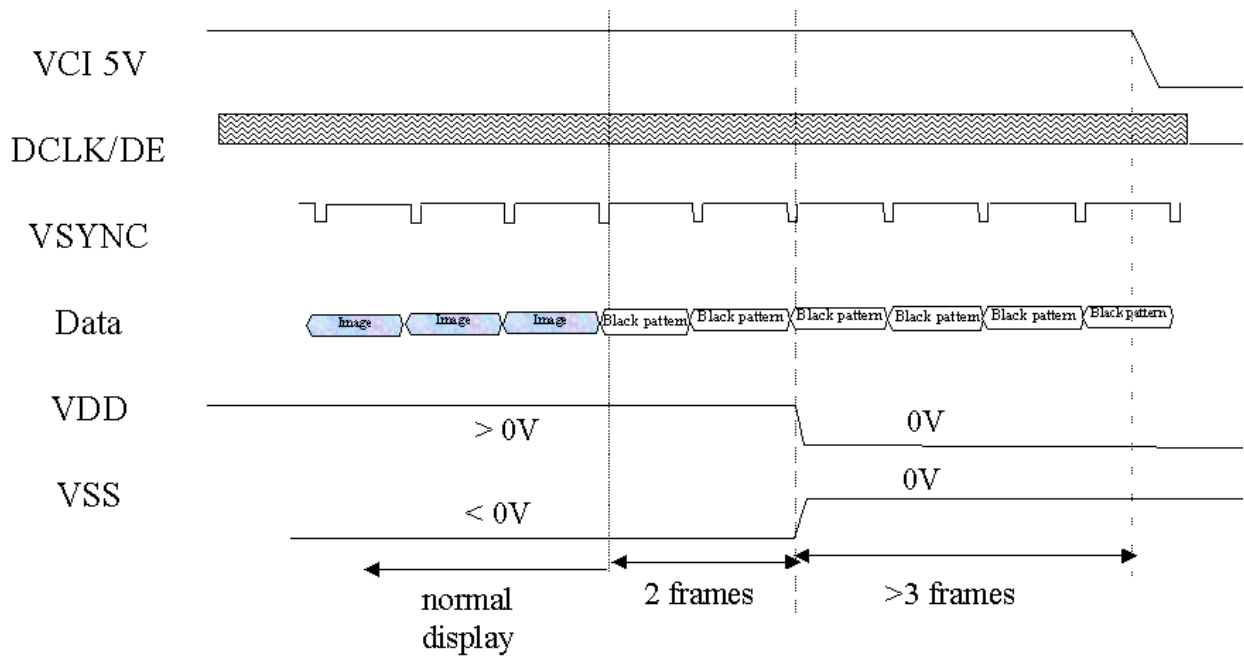

10. Brightness control

Index_out(0x11); Parameter_out(0x20); //set brightness

Example: if the target specification is 200nit in white pattern.

Index_out(0x11); Parameter_out(0x20); => 200nit

Index_out(0x11); Parameter_out(0x1D); => 170nit

Index_out(0x11); Parameter_out(0x1C); => 150nit

Index_out(0x11); Parameter_out(0x19); => 125nit

Index_out(0x11); Parameter_out(0x17); => 100nit

Index_out(0x11); Parameter_out(0x14); => 75nit

Index_out(0x11); Parameter_out(0x11); => 50nit

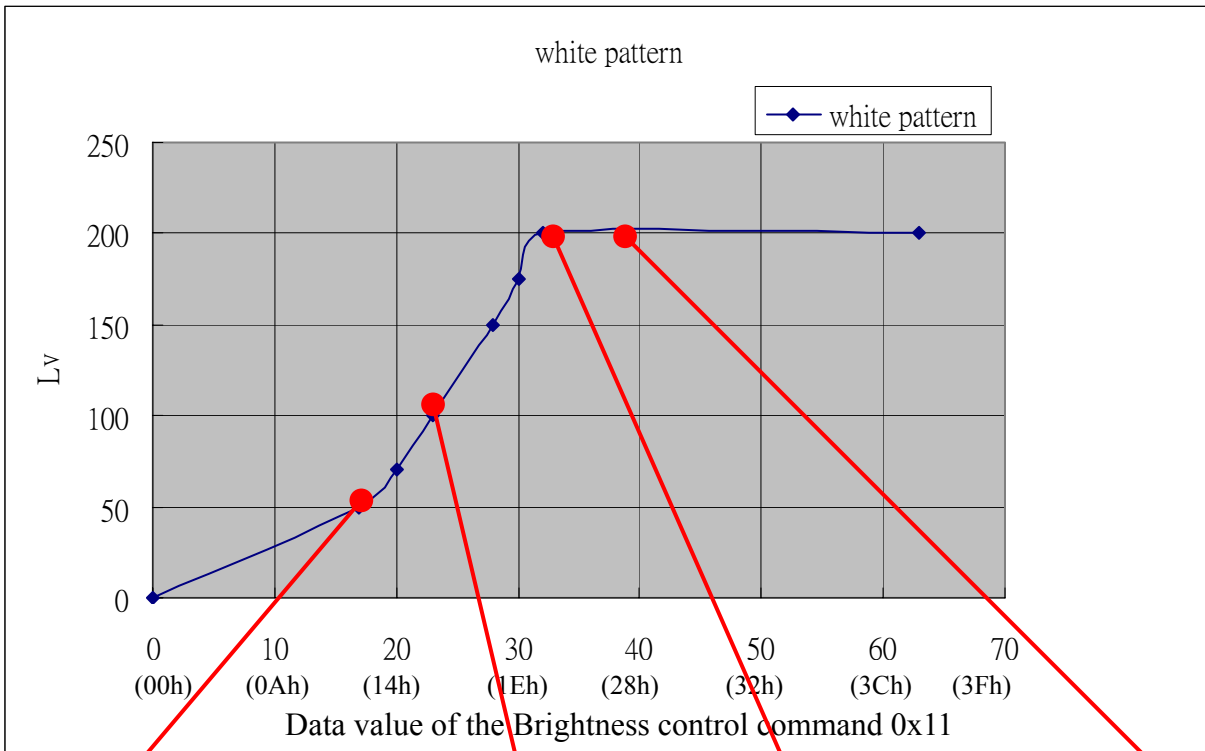

Parameter_out(0x11)



Parameter_out(0x17)



Parameter_out(0x20)



Parameter_out(0x24)

12. Reliability Test:

No.	Items	Specification
1	High Temp. Storage	85°C, 240hrs
2	Low Temp. Storage	-40°C, 240hrs
3	High Temp. Operation	60°C, 240hrs
4	Low Temp. Operation	-40°C, 240hrs
5	High Temp / Humidity Storage	85°C, 85%RH, 240hrs
6	High Temp / Humidity Operation	60°C, 90%RH, 240hrs
7	Thermal shock	-40°C ~85°C (-40°C /30min; transit/3min; 85°C /30min; transit /3min) 1cycle: 66min, 100 cycles
8	Vibration	Frequency: 5~50HZ, 0.5G Scan rate: 1 oct/min Time: 2 hrs/axis Test axis: X, Y, Z
9	Drop	Height: 76cm Sequence : 1 angle 、 3 edges and 6 faces Cycles: 1
10	ESD	Air discharge model, ±8kV, 10 times

Test and measurement conditions

- All measurements shall not be started until the specimens attain to temperature stability.
- The degradation of polarizer is ignored for item 1, 5 & 6.
- The test pattern at operating condition is 30%P.C. alternating pictures.

Evaluation Criteria

- No damage to glass or encapsulation
- No drastic change to display
- Defects / Mura follow product specification
- Luminance: Within +/-50% of initial value
- Current consumption: within +/-50% of initial value

13. Handling:

- 13.1 Do not scratch the surface of the polarizer film as it is easily damaged.
- 13.2 When cleaning the display surface, use soft cloth with solvent (as recommended below) and wipe lightly
 - Ethyl alcohol
 - Isopropyl alcohol
- 13.3 Do not wipe the display surface with dry or hard materials that damage the polarizer surface.
- 13.4 Since this OLED panel is made of glass, dropping the module or banging it against hard objects may cause cracks or fragmentation.
- 13.5 Do not disassemble the OLED module as it may cause permanent damage.
- 13.6 Hold OLED very carefully when placing OLED module into the system housing. Do not excessive stress or pressure to OLED module.

14. Storage

- 14.1 Storing in a polyethylene bag with the opening sealed.
- 14.2 Placing in a dark place where neither exposure to direct sunlight nor any fluorescent light is permitted and keep at room temperature & room humidity.
- 14.3 Storing with no contact with polarizer surface.
(It is recommended to store them in the inner container which we delivered.)

15. Panel ID Label Naming Rule

- 15.1 Single format example:

OSD0760WVGA-T	Model ID(Gamma Code)
T1895066NG0113	Panel ID
A882501EL100013A	Module Information

16. Package:

1. One tray with 2 pcs panel module.

2. Take EPE sheet 1 pcs above the tray.

3. Take empty tray 1 pcs top of the substantial tray.

4. Circle the apex(3X897) over 1 loops around and fixed the trays.

5. Place core stack with a Drier into an anti-static bag.

6. Use clean tape to seal the bag.

7. Take EPE foam 2 pcs to hold one Bag.

8. Place three stacks into the carton.

9. One box package

1. One tray with 2 pcs panel module.

2. Take EPE sheet 1 pcs above the tray.

3. Take empty tray 1 pcs top of the substantial tray.

4. Circle the apex(3X897) over 1 loops around and fixed the trays.

5. Place core stack with a Drier into an anti-static bag.

6. Use clean tape to seal the bag.

7. Take EPE foam 2 pcs to hold one Bag.

8. Place three stacks into the carton.

9. One box package

① Tray

② EPE Sheet

x 1pc(Empty)

x 3pc(Panel 10pcs)

④ Drier

⑤ Anti-Static Vacuum Bag

⑦ EPE Foam

⑧ Carton Lobe(Must align the corner point)

⑨ Carton

Connector direction must follow the arrowhead

MP number label must upturn

Interface Stock

Final Hot Sealing

S/N Label

9	Carton	1	box	78-X000009
8	Carton Label	1	pc	78-X000011
7	EPE Foam	6	pc	78-X000002
6	S/N Label	3	pc	78-X000008
5	Anti-Static vacuum bag	3	pc	78-X000005
4	Drier	3	pc	78-X000001
3	Packing Tape	2	pc	78-2000074/75
2	EPE Sheet	15	pc	78-X000059
1	Tray	18	pc	78-X000058

TITLE		REV: 00	
Approved	J.C. GDI	Drawing No.	
Checked	Edward Huang	Part No.	
Drawn	Ulysses	Natural	
Designer	Ulysses	Date	Shp-08-00
		Scale	
		Sheet	1 / 1
		Item	M

ALL RIGHTS RESERVED. COPYING FORBIDDEN.

17. Warranty

Warranty term is 12 months of reliability characteristics of quality level after the outgoing date from OSD Displays.

OSD Displays could compensate for defectives, which happen within warranty term under condition that products should be stored or be used as specified under normal condition within the contents of specification.

Otherwise, it is unable to compensate for defectives when below items happen:

- (1) Defectives happen by customer's mistake such as careless handling or design change, etc.
- (2) Defectives caused by natural uncontrolled disaster.
- (3) The direct and/or indirect damage caused by unapproved or disagreed use behavior, condition, environment, which is over or not belong to the product specification or other related technique document published by OSD Displays.

After 12 months of warranty term, all replacement for defectives will be charged.